

US-STYLE SHOWCASE : SHELF PEG INSTALLATION

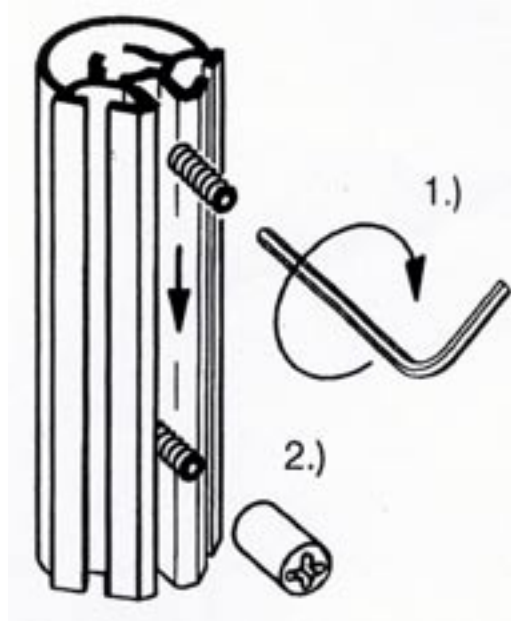

- 1** Insert threaded stud into center grooved channel (see figure above) AFTER ascertaining desired shelf position, screw threaded stud in so that it seats all the way to the back of the grooved channel.
- 2** With threaded stud properly seated, install 30mm threaded barrel. Tighten barrel with phillips head screw driver until barrel cinches tight against vertical extrusion.

PLEASE NOTE: THESE INSTRUCTIONS ARE SUBJECT TO CHANGE WITHOUT NOTICE.



Peter Pepper Products, Inc. • T: 310.639.0390 x 7 • F: 310.639.6013 • E: customerservice@peterpepper.com