

UC Board and Frame 5 Mounting Guide

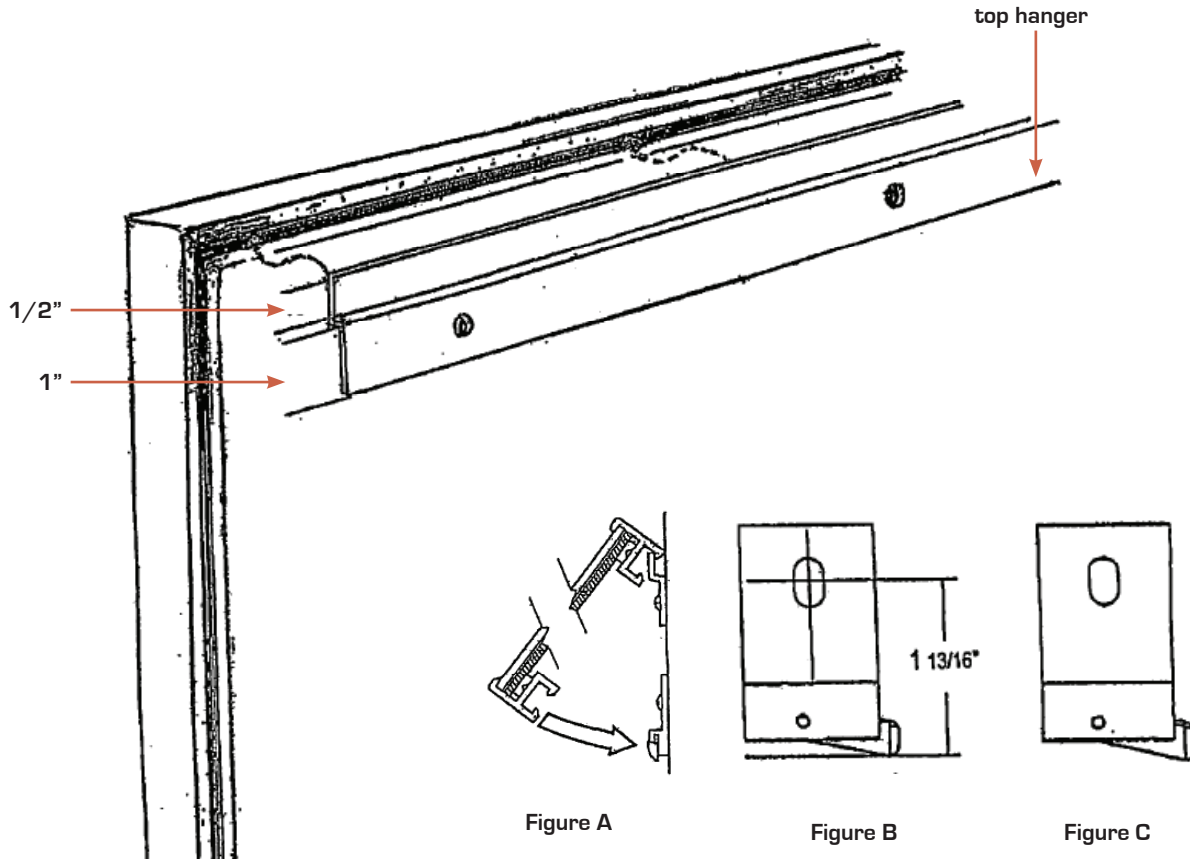

Mounting Instructions

1. Attach the TOP HANGER to the wall at the desired elevation (see FIGURE A).
2. With the FRAME hanging from the TOP HANGER, draw a light horizontal pencil mark on the wall near the center bottom of the frame. Ideally, this is where the frame meets the wall.
3. Remove the FRAME from the HANGERS. Locate the hole for the security lock 1-13/16" up from the mark (see FIGURE B).
4. Fasten the SECURITY LOCK to the wall. Place the FRAME on the HANGERS and guide the FRAME until the bottom of the FRAME engages the lock mechanism. The lock will "click" when properly secured to the wall.

Should the FRAME not "click" into place, the LOCK may need adjusting. Loosen the SECURITY LOCK FASTENER and adjust up or down until properly adjusted (see FIGURE C).

See below table for mounting suggestions:

Locks Included	Unit Width	Mounting
1	12-48"	Center
2	60-96"	8" from each end
3	>96"	8" from each end and center